

# SF30BA

## General Specifications

Circuit	:SP5T (Switch element)
Current Rating	:50mA @ 12VDC
Contact Resistance	:500m Ohm Max.(initial)
Insulation Resistance	:100MOhm Min.
Operating Force	:400gf±200gf(S1~4) :250gf±100gf(S5)
Total Travel	:0.5mm ± 0.3mm
Mechanical Life	:200,000 cycles Min.
Operating Temperature	:-25 deg.~+60 deg.
Solder Specifications	:260 deg. for 3 seconds

## Materials

Housing	:Aluminum
Cap	:Polycarbonate (PC)
Reflector	:Silicone
Nuts	:Polyamide(PA)
Base	:Acrylonitrile Butadiene Styrene (ABS)
Washer	:NBR
SUS Washer	:SUS

## Application

- Industrial equipment
- Public building
- CNC Machine tool
- Medical equipment
- Robot
- Transportation

## Feature

- Panel cutting Ø30mm
- Front Panel IP65
- 5 Key Navigation Switches
- LED Illuminated
- Metal Housing



## Dimension

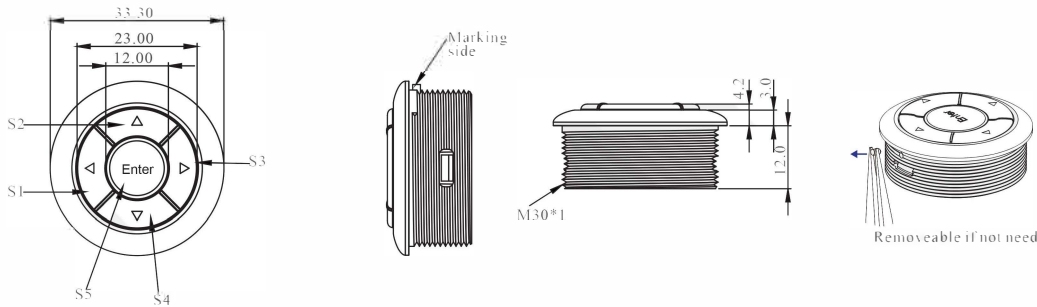

## Contact Configuration & Installation Notes & Panel Cutting

1	2	3	4	5	6	7	8	9	10	11	12
Pin	Function	Pin	Function								
1	SW COM.	7	LED (+)								
2	SW 1 N.O.	8	SW 1 LED(-)								
3	SW 2 N.O.	9	SW 2 LED(-)								
4	SW 3 N.O.	10	SW 3 LED(-)								
5	SW 4 N.O.	11	SW 4 LED(-)								
6	SW 5 N.O.	12	SW 5 LED(-)								

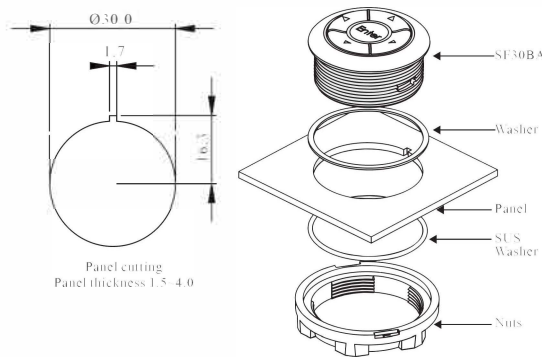

## Option

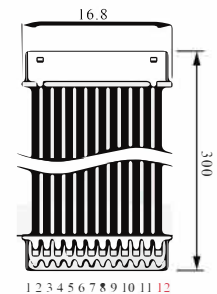

Cable: YCW024  
Conductor pitch / 1.25mm  
Conductor width / □0.3mm

## How to Order

Module			
Part No	SF30BA4051	SF30BA5551	SF30BA7051
Description	White LED Silver bezel Black cap Marking 1	Pure Green LED Black bezel Black cap Marking 1	Blue LED Silver bezel Black cap Marking 1

※ Color is subject to actual product.  
※ We provide Marking service.