

15.0×7.5×9.4



Features
<ul style="list-style-type: none"> • DIL pitch terminals .Surface mount type with “L” shaped terminal; • Conforms to FCC Part 68 2.5kV Surge and Dielectric 1500VAC; • High contact capacity 2A/30VDC; • Application for Telecommunication Equipment,Office Equipment, Security Alarm Systems, Measuring instruments, Medical Monitoring Equipment,Audio Visual Equipment, Flight Simulator,Sensor Control.

Ordering Information
<p>NX 2 SA L H 12 W</p> <p>1 2 3 4 5 6 7</p>
<p>1 Part number: NX 2 Contact arrangement: 2:2C 3 Mount: NIL:DIL; SA: Standard SMT; SL: High connection reliability SMT 4 Operating function: Nil: Single Side Stable; L:1 Coil Latching 5 Terminal: NIL: Standard DIL or SMT; H:Self-clinching terminal 6 Coil rated Voltage(V): DC:3,4,5,5,6,9,12,24 7 Contact Material: NIL:AgPd W:AgNi</p>

Contact Data	
Contact Arrangement	2C (DPDT(B-M)) (Bifurcated Crossbar)
Contact Material	AgPd(Gold clad) AgNi(Gold clad)
Contact Rating (resistive)	1A,2A/30VDC 0.5A/125VAC
Max. Switching Power	60W, 62.5VA Min. Switching load: 0.01mA/10mV (Reference Value)
Max. Switching Voltage	220VDC, 250VAC Max. Switching Current:2A
Contact Resistance or Voltage drop	≤70mΩ(80 mΩSMT) Item 4.12 of IEC 61810-7
Operational life	Electrical 1A/30VDC: 5 × 10 ⁵ 1 × 10 ⁵ Item 4.30 of IEC 61810-7
	Mechanical 10 ⁶ Item 4.31 of IEC 61810-7

CAUTION:
 Relays previously tested or used above 10mA resistive at 6V maximum (DC or peak AC) open circuit are not recommended for subsequent use in low level applications.

Coil Parameter

Dash numbers	Coil voltage VDC		Coil resistance Ω ± 10%	Pick up voltage VDC(max) (75%of rated voltage)	Release voltage VDC(min) (10% of rated voltage)	Coil power W	Operate Time ms	Release /Reset Time ms
	Rated	Max.						
NX2-003	3	4.5	64.3	2.25	0.3	0.14		
NX2-004	4.5	6.7	145	3.38	0.45	0.14		
NX2-005	5	7.5	178	3.75	0.5	0.14		
NX2-006	6	9.0	257	4.50	0.6	0.14	<4	<4
NX2-009	9	13.5	579	6.75	0.9	0.14		
NX2-012	12	18.0	1028	9.00	1.2	0.14		
NX2-024	24	36.0	2880	18.0	2.4	0.20		
1 Coil Latching						Reset(Max)		Reset
NX2L-003	3	4.5	90	2.25	-2.25	0.10		
NX2L-004	4.5	6.7	202.5	3.38	-3.38	0.10		
NX2L-005	5	7.5	250	3.75	-3.75	0.10		
NX2L-006	6	9.0	360	4.50	-4.50	0.10	<4	<4
NX2L-009	9	13.5	810	6.75	-6.75	0.10		
NX2L-012	12	18.0	1440	9.00	-9.00	0.10		
NX2L-024A	24	36.0	3840	18.0	-18.0	0.15		

Coil Parameter

Dash Numbers	Coil voltage VDC		Coil resistance $\Omega \pm 10\%$	Pick up voltage VDC(max) (75% of rated voltage)	Release voltage VDC(min) (10% of rated voltage)	Coil power W	Operate Time ms	Release /Reset Time ms
	Rated	Max.						
NX2SA-003	3	4.5	64.3	2.25	0.3	0.14	<4	<4
NX2SA-004	4.5	6.7	145	3.38	0.45	0.14		
NX2SA-005	5	7.5	178	3.75	0.5	0.14		
NX2SA-006	6	9.0	257	4.50	0.6	0.14		
NX2SA-009	9	13.5	579	6.75	0.9	0.14		
NX2SA-012	12	18.0	1028	9.00	1.2	0.14		
NX2SA-024	24	36.0	2880	18.0	2.4	0.20		
1 Coil Latching					Reset(Max)			Reset
NX2SAL-003	3	4.5	90	2.25	-2.25	0.10	<4	<4
NX2SAL-004	4.5	6.7	202.5	3.38	-3.38	0.10		
NX2SAL-005	5	7.5	250	3.75	-3.75	0.10		
NX2SAL-006	6	9.0	360	4.50	-4.50	0.10		
NX2SAL-009	9	13.5	810	6.75	-6.75	0.10		
NX2SAL-012	12	18.0	1440	9.00	-9.00	0.10		
NX2SAL-024A	24	36.0	3840	18.0	-18.0	0.15		
1 Coil Latching					Reset(Max)			Reset
NX2SL-003	3	4.5	64.3	2.25	0.3	0.14	<4	<4
NX2SL-004	4.5	6.7	145	3.38	0.45	0.14		
NX2SL-005	5	7.5	178	3.75	0.5	0.14		
NX2SL-006	6	9.0	257	4.50	0.6	0.14		
NX2SL-009	9	13.5	579	6.75	0.9	0.14		
NX2SL-012	12	18.0	1028	9.00	1.2	0.14		
NX2SL-024	24	36.0	2880	18.0	2.4	0.20		
1 Coil Latching					Reset(Max)			Reset
NX2SLL-003	3	4.5	90	2.25	-2.25	0.10	<4	<4
NX2SLL-004	4.5	6.7	202.5	3.38	-3.38	0.10		
NX2SLL-005	5	7.5	250	3.75	-3.75	0.10		
NX2SLL-006	6	9.0	360	4.50	-4.50	0.10		
NX2SLL-009	9	13.5	810	6.75	-6.75	0.10		
NX2SLL-012	12	18.0	1440	9.00	-9.00	0.10		
NX2SLL-024A	24	36.0	3840	18.0	-18.0	0.15		

- CAUTION:**
- 1.The use of any coil voltage less than the rated coil voltage will compromise the operation of the relay.
 - 2.Pickup and release(reset) voltage are for test purposes only and are not to be used as design criteria.
 - 3.When latching relays are installed in equipment, the latch and reset coil should not be powered simultaneously. Coil should not be pulsed with less than the nominal coil voltage and pulse width should be a minimum of three times the specified operate time of the relay. If these conditions are not followed, it is possible for the relay to be in the magnetically neutral position .
 - 4.Unless otherwise stated, the rated coil voltage specified in coil parameter and its suitable polarity(if applicable) shall be used for all tests and its application to the relay.
 - 5.Soldering and mounion recommendations for NX as same as P series.

Characteristics

Insulation Resistance	1000M Ω min (at 500VDC)	Item 7 of IEC 60255-5
Dielectric Strength		
Between open Contacts	1000VAC 1min	Item 6 of IEC 60255-5
Between coil & Contacts	1500VAC 1min	
Between Contact Poles	1000VAC 1min	Item 6 of IEC 60255-5
Surge Withstand Voltage		
Between open Contacts	1500V	FCC 68
Between coil & Contacts	2500V	FCC 68
Shock resistance	Functional:750m/s ² 11ms; Survival:1000 m/s ² 6ms	IEC 68-2-27 Test Ea
Vibration resistance	10Hz~55Hz Double amplitude Functional:3.3mm Survival:5mm	IEC 68-2-6 Test Fc
Terminals strength	5N	IEC 68-2-21 Test Ua1
Solderability	235 $\text{C} \pm 2\text{C}$ 3s \pm 0.5s 215 $\text{C} \pm 3\text{C}$ 3s \pm 0.3s(only for SL type)	IEC 68-2-20 Test Ta method 1 IEC 68-2-58 Test Td
Temperature Range	-40 C ~85 C (-40 $^{\circ}$ F~185 $^{\circ}$ F)	
Relative Humidity	5% to 85%	IEC 68-2-3 Test Ca
Mass	Approx. 2g	

Safety approvals

Safety approval	UL&CUR
Load	0.5A/125VAC 2A/30VDC

Dimensions

mm/inch

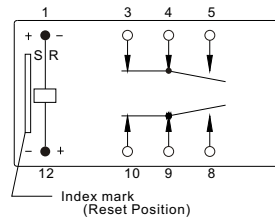
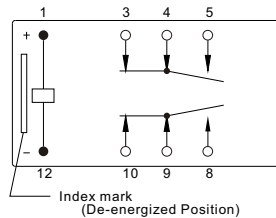
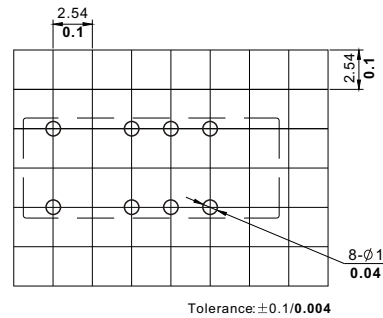
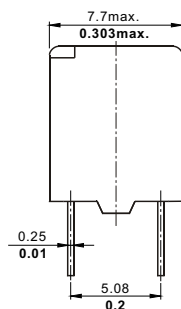
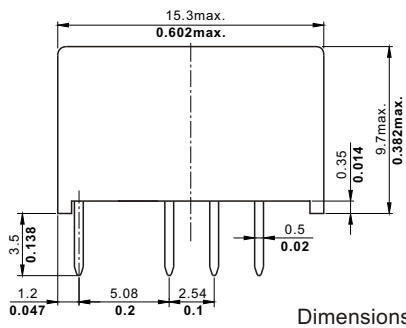

S: Set
R: Reset
(Bottom View)

Wiring diagram(Bottom view)

NOTES 1).Dimensions are in millimeters.
2).Inch equivalents are given for general information only.

Dimensions

mm/inch

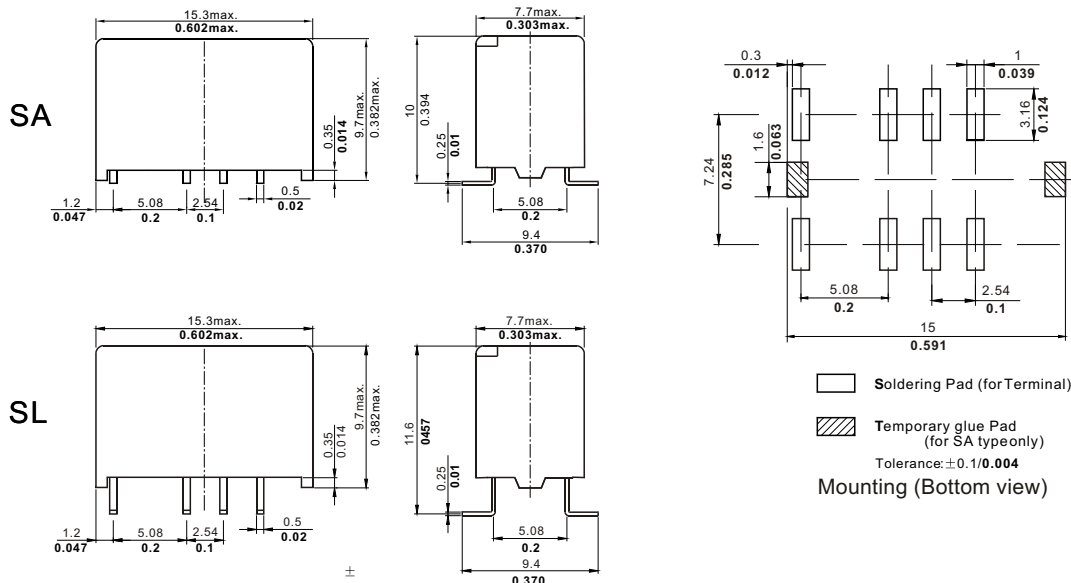

Dimensions

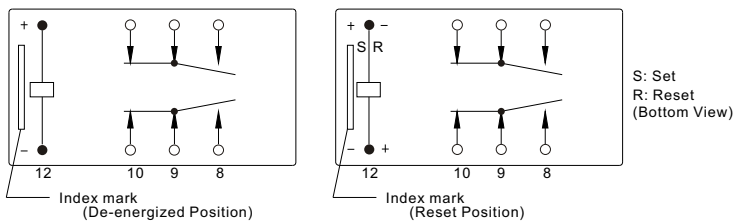

Wiring diagram(Bottom view)

NOTES 1).Dimensions are in millimeters.
 2).Inch equivalents are given for general information only.