

SPECIFICATIONS

CONTACT RATING: Dependent upon contact material See Page 68.

MECHANICAL LIFE: 30,000 make-and-break cycles.

CONTACT RESISTANCE: 20 mΩ max. initial @ 2-4VDC
100mA for both silver and gold plated contacts.

INSULATION RESISTANCE: 1,000 MΩ min.

DIELECTRIC STRENGTH: 1,000 Vrms min.@sea level.

OPERATING TEMPERATURE: -30°C to 85°C.

MATERIALS

CASE: Diallyl phthalate (DAP) (UL94v-0).

ACTUATOR: Nylon,black std.

BUSHING: Brass or Zinc,nickel plated.

HOUSING: Stainless Steel.

SWITCH SUPPORT: Brass,tin plated.

TERMINAL/CONTACT: Brass,with silver or gold .(See Page 68)



SWITCH FUNCTION

NO. POLES	UL/CSA MODEL NO.	MODEL NO.	SWITCH FUNCTION			CONNECTED TERMINALS / SCHEMATIC		
			POS.1	POS.2	POS.3	POS.1	POS.2	POS.3
SP	Q2411	4MS1	ON	NONE	ON	2-3	N/A	2-1
	Q2412	4MS2	ON	NONE	MOM			
	Q2413	4MS3	ON	OFF	ON	OPEN		
	Q2414	4MS4	MOM	OFF	MOM			
	Q2415	4MS5	ON	OFF	MOM	OPEN		N/A
	Q2416	4MS6	OFF	NONE	ON			
DP	Q2421	4MD1	ON	NONE	ON	2-3,5-6	N/A	2-1,5-4
	Q2422	4MD2	ON	NONE	MOM			
	Q2423	4MD3	ON	OFF	ON	OPEN		

MOM=MOMENTARY

POLE OPTIONS

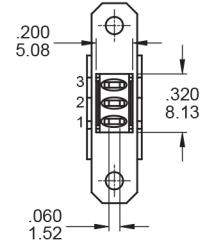
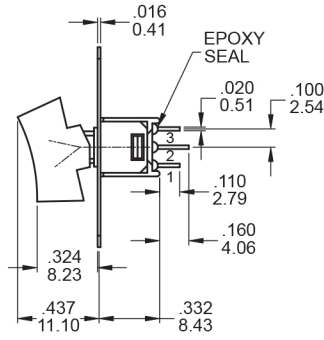
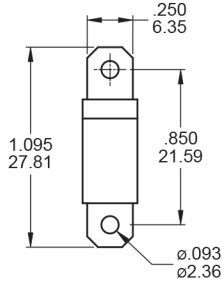
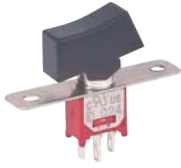

SPDT

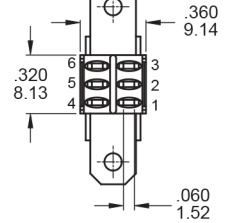
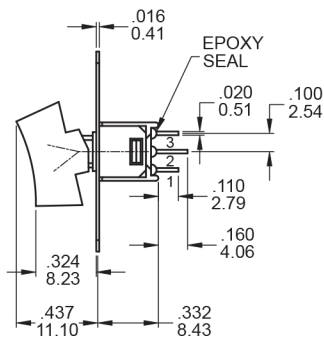
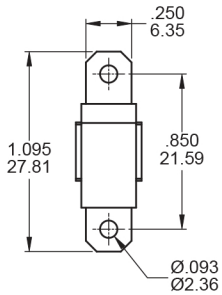
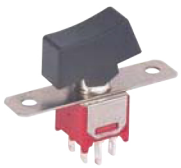

DPDT

ACTUATOR OPTIONS - PANEL MOUNT

R1

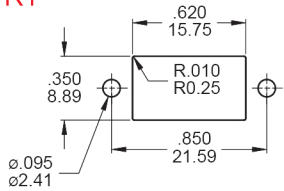

PANEL MOUNTING-R1

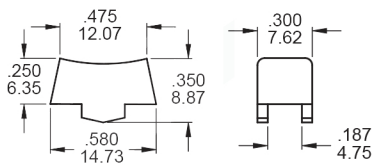

R2

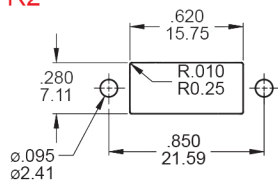

PANEL MOUNTING-R2

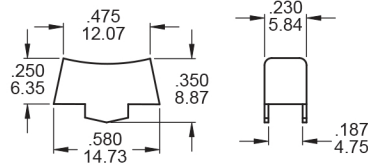

R3

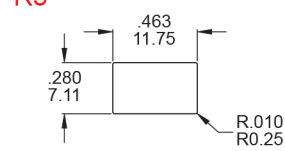

PANEL MOUNTING-R3

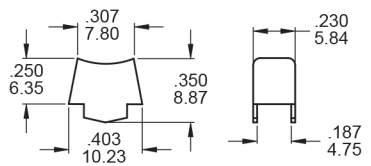

TERMINATION OPTIONS

M1 Solder lug

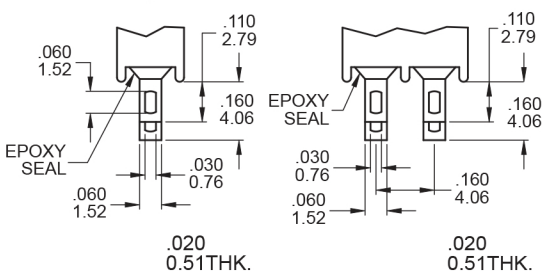

Double Pole

M2 PC Thru-hole

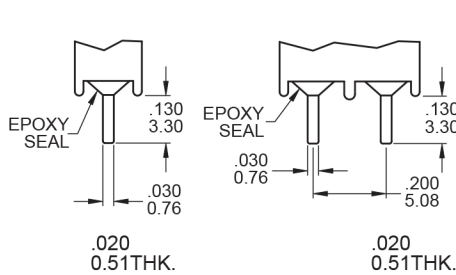

Double Pole

M5 Wire Wrap

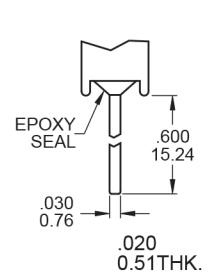

M6

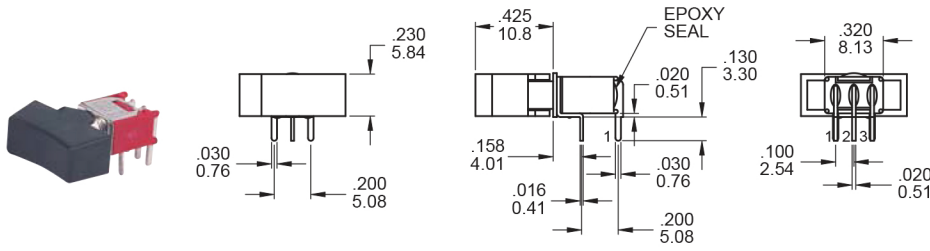

P.C. MOUNTING

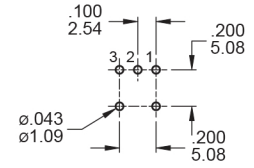

SPDT

M6

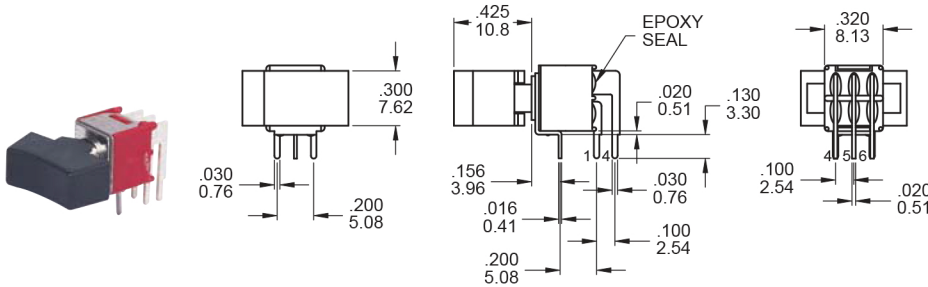

P.C. MOUNTING

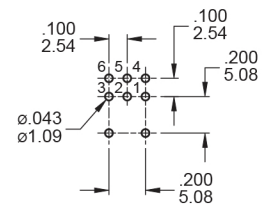

DPDT

M7

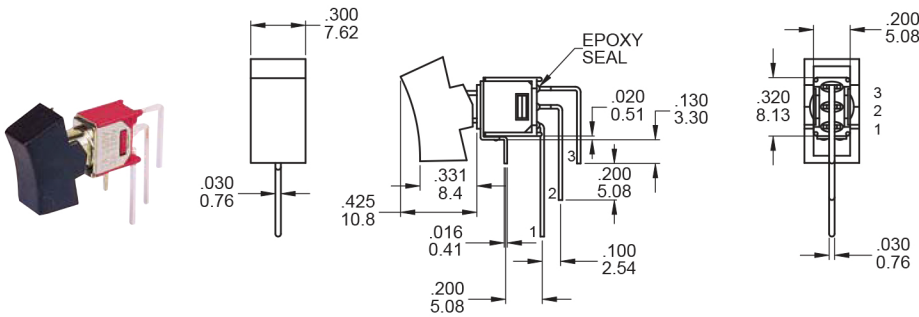

P.C. MOUNTING

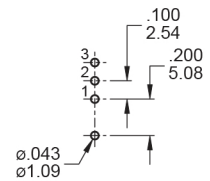

SPDT

M7

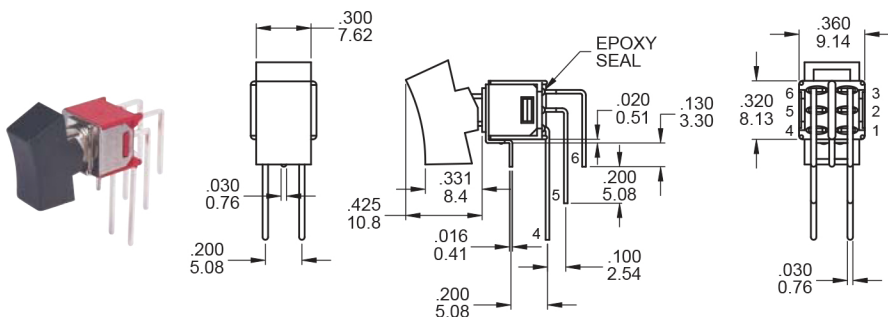

P.C. MOUNTING

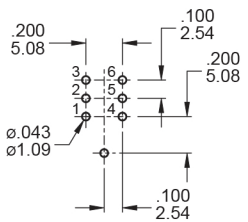

DPDT



VS2 - VS3

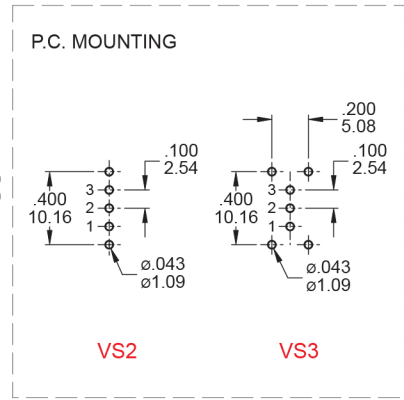
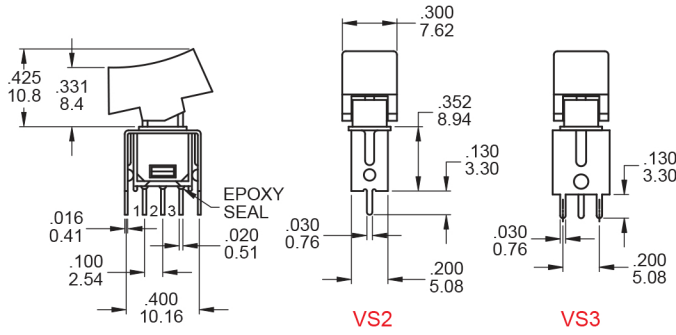

SPDT

Part No. Shown : 4MS1R102VS2QE

VS2 - VS3

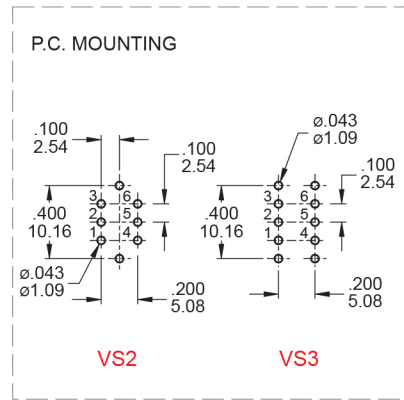
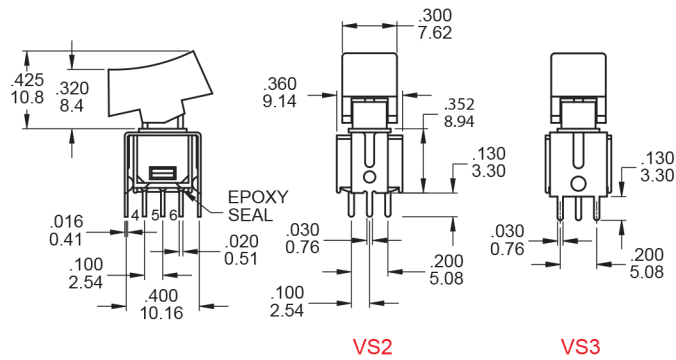

DPDT

Part No. Shown : 4MD1R102VS2QE

SNAP-IN TERMINATION OPTIONS

M6N



M7N

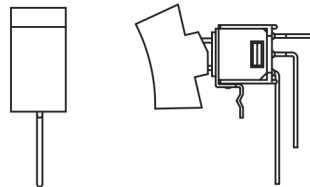

V2N

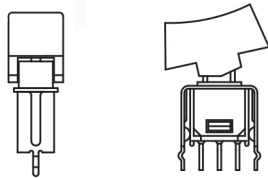

V3N

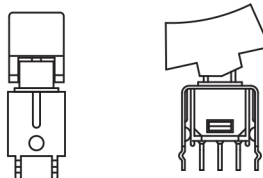

CONTACT MATERIAL OPTIONS

	CONTACT PLATING	TERMINAL PLATING	RATINGS
Q	Silver	Q = Silver	3 Amps with resistant load @ 120VAC or 28VDC 1 Amps with resistant load @ 250VAC
S		S = Silver,pure - tin	
C	Gold over Silver	C = Gold over silver	0.4 Volt - Amps (VA) max. @ 20V max. (AC or DC)
K		K = Gold over silver,pure - tin	
R	Gold	R = Gold	0.4 Volt - Amps (VA) max. @ 20V max. (AC or DC)
G		G = Gold,pure - tin	

SOLDERING PROCESSES

MANUAL SOLDERING: Use soldering iron of 30 watts, controlled at 350°C approximately 5 seconds while applying solder.

WAVE SOLDERING: Recommended Soldering Temperature: 260 ± 5°C

Duration of Solder Immersion: Max 5 sec. (PCB is 1.6mm in thickness)

